

DH-IPC-EBW81200

12M Ultra HD Vandal-proof IR Network Fisheye Camera



Features

- 1/2.3" 12M progressive scan CMOS
- H.264 & MJPEG dual-stream encoding
- Max 15fps@12M(4000x3000), 25/30fps@3M(2048x1536)
- Multiple Correct Mode: Original, Panoramic, Double Panoramic, 1+3, Eptz, 4 pictures
- DWDR, Day/Night(ICR), 3DNR, ROI, AWB, AGC, BLC
- Multiple network monitoring: Web viewer, CMS(DSS/PSS) & DMSS
- Max.IR LEDs Length 10m
- 1/1 Audio in/out(Built in Mic)
- Micro SD memory, IP67, IK10, PoE

DH-IPC-EBW81200

Technical Specifications

Model	IPC-EBW81200	
Camera		
Image Sensor	1/2.3" 12M progressive scan CMOS	
Effective Pixels	4000 (H) *3000 (V)	
Scanning System	Progressive	
Electronic Shutter Speed	Auto/Manual 1/3~1/10000	
Min. Illumination	0.01Lux/F2.2(Color), 0Lux/F2.2(IR on)	
S/N Ratio	More than 50dB	
Video Output	N/A	
Camera Features		
Max. IR LEDs Length	10m	
Day/Night	Auto(ICR) / Color / B/W	
Backlight Compensation	BLC/ HLC/DWDR	
White Balance	Auto/Manual	
Gain Control	Auto/Manual	
Noise Reduction	3D	
Privacy Masking	Up to 4 areas	
Lens		
Focal Length	1.57mm	
Max Aperture	F2.2	
Focus Control	Manual	
Angle of View	185° /185° /185°	
Lens Type	Manual	
Mount Type	Board-in Type	
Video		
Compression	H.264H/MJPEG/JPEG	
Resolution	12M(4000×3000)/8M(2880×2880)/6M(2880×2160)/3M(2048×1536)	
Frame Rate	Main Stream	12M(1~15fps)/3M (1 ~ 25/30fps)
	Sub Stream	D1/CIF(1 ~ 25/30fps)
Bit Rate	40Kbps~8192Kbps	
Correct Mode	Original ,Panoramic, Double Panoramic,1+3,Eptz,4 pictures	
Audio		
Compression	G.711a/G.711u/PCM	
Interface	1/1 channel In/Out(Built in Mic)	
Network		
Ethernet	RJ-45 (10/100Base-T)	
Wi-Fi	N/A	
Protocol	HTTP,TCP,ARP,RTSP,RTMP,UDP,RTCP,SMTP,FTP,DHCP,DNS,DDNS,PPPOE, IPv4/v6,SNMP,QoS,UPnP,NTP	
Compatibility	ONVIF,PSIA,CGI	

DH-IPC-EBW81200

Max. User Access	20users
Smart Phone	iPhone, iPad, Android, Windows Phone
Auxiliary Interface	
Memory Slot	Micro SD
RS485	N/A
Alarm	2/1 channel In/Out
PIR Sensor Range	N/A
General	
Power Supply	DC12V, PoE (802.3af)
Power Consumption	<13W
Working Environment	-30°C~ +60°C, Less than 95%RH
Ingress Protection	IP67
Vandal Resistance	IK10
Dimensions	Φ150mm x 50.7mm
Weight	0.58kg(0.86kg with packaging)

DH-IPC-EBW81200

Dimensions (mm)

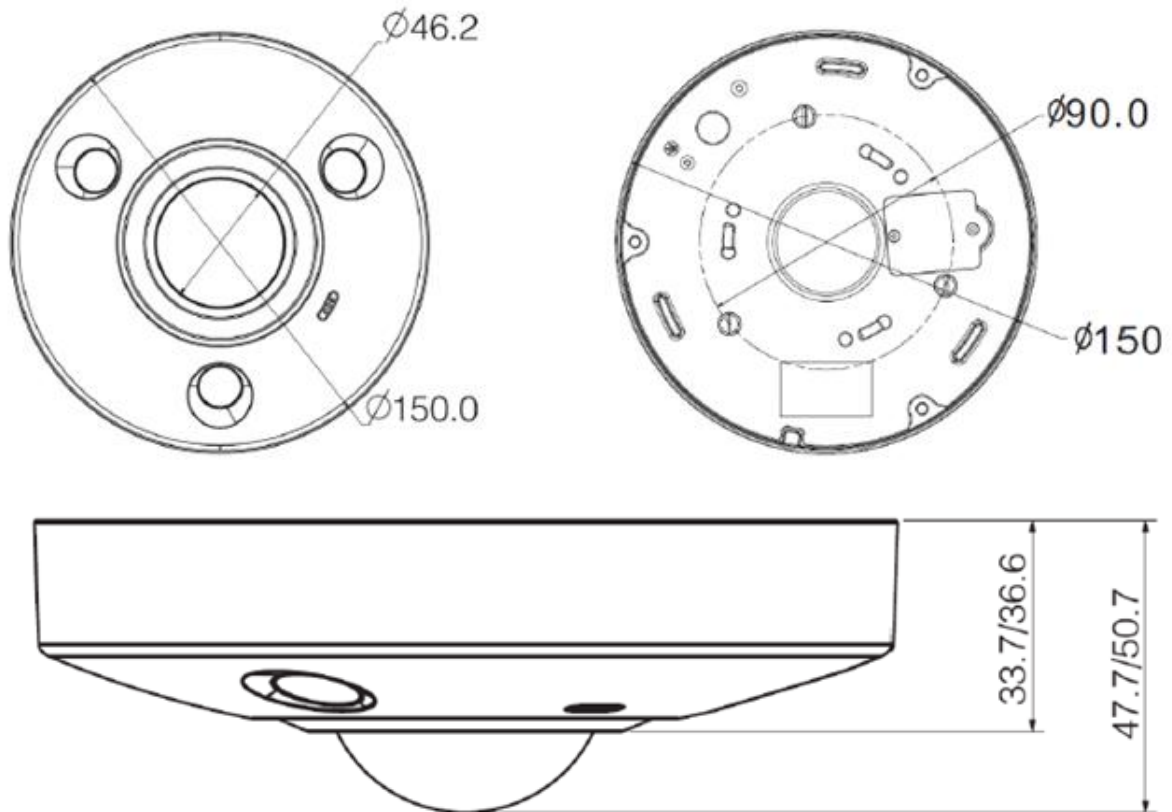

Accessories (optional)

				
PFA100	PFB302S	PFA132	PFA152	PFA151

DH-IPC-EBW81200

1199 BinAn Road, Binjiang District, Hangzhou, China

Tel: +86-0571-87688883

Fax: +86-0571-87688815

Email: overseas@dahuatech.com

www.dahuatech.com

*Design and specifications are subject to change without notice.

© 2014 Dahua Technology Co., Ltd.