

DH-IPC-EB5500

5MP Vandal-proof Network Fisheye Camera



Features

- 1/3" 5Megapixel progressive scan CMOS
- H.264 & MJPEG dual-stream encoding
- Max 12fps@5M(2560×1920), 25/30fps@UXGA
- Day/Night(Electronic), 3DNR, AWB,AGC,BLC
- Multiple network monitoring: Web viewer, CMS(DSS/PSS) & DMSS
- 1.42mm fixed lens
- Micro SD memory, IK10, PoE

DH-IPC-EB5500

Technical Specifications

Model	DH-IPC-EB5500	
Camera		
Image Sensor	1/3" 5Megapixel progressive scan CMOS	
Effective Pixels	2592(H)x1944(V)	
Scanning System	Progressive	
Electronic Shutter Speed	Auto/Manual 1/3(4)~1/100000s	
Min. Illumination	0.01lux/F2.6(color) ,0.001Lux@F2.6(B/W)	
S/N Ratio	More than 50dB	
Video Output	N/A	
Camera Features		
Max. IR LEDs Length	N/A	
Day/Night	Auto(Electronic)/Color/B/W	
Backlight Compensation	BLC/HLC/DWDR	
White Balance	Auto/Manual	
Gain Control	Auto/Manual	
Noise Reduction	3D	
Privacy Masking	Up to 4 areas	
Lens		
Focal Length	1.42mm	
Max Aperture	F2.6	
Focus Control	Manual	
Angle of View	H:185°	
Lens Type	Fixed lens	
Mount Type	Board-in Type	
Video		
Compression	H.264/ MJPEG	
Resolution	5M(2560×1920)/3M(2048×1520)/UXGA(1600×1200)/1.3M(1280×960)/720P(1280×720)/D1(704×576/704×480)/CIF(352×288/352×240)	
Frame Rate	Main Stream	5M(1~12fps)/ UXGA (1 ~ 25/30fps)
	Sub Stream	D1/CIF(1 ~ 25/30fps)
Bit Rate	H.264: 20K ~ 8192Kbps	
Audio		
Compression	G.711a/G.711u/PCM	
Interface	1/1 channel In/Out(Built in Mic)	
Network		
Ethernet	RJ-45 (10/100Base-T)	
Wi-Fi	N/A	
Protocol	IPv4/IPv6, HTTP, HTTPS, SSL, TCP/IP, UDP, UPnP, ICMP, IGMP, SNMP, RTSP, RTP, SMTP, NTP, DHCP, DNS, PPPOE, DDNS, FTP, IP Filter, QoS, Bonjour	
Compatibility	ONVIF,PSIA,CGI	

DH-IPC-EB5500

Max. User Access	20 users
Smart Phone	iPhone, iPad, Android, Windows Phone
Auxiliary Interface	
Memory Slot	Micro SD, Max 64GB
RS485	N/A
Alarm	1/1 channel In/Out
PIR Sensor Range	N/A
General	
Power Supply	DC12V,PoE
Power Consumption	Max 6W
Working Environment	-30°C~+60°C, Less than 95% RH
Ingress Protection	N/A
Vandal Resistance	IK10
Dimensions	Φ110mm×54mm
Weight	0.25kg

DH-IPC-EB5500

Dimensions (mm)

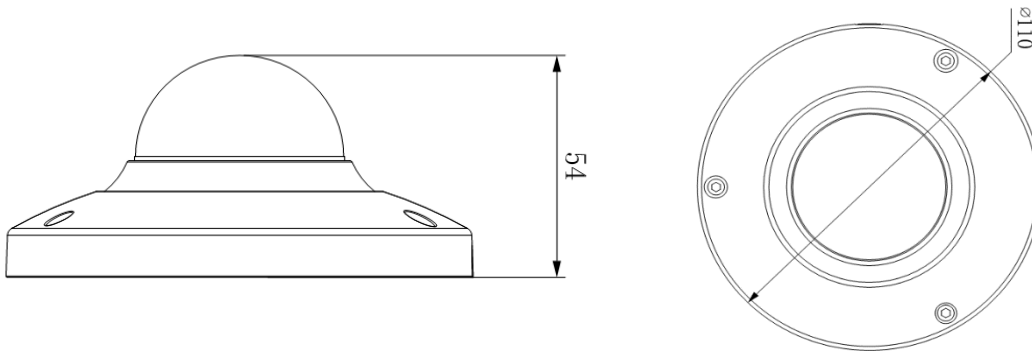

Accessories (optional)

		
PFB200W	PFA131	PFA123

Dahua Technology Co., Ltd.

1199 BinAn Road, Binjiang District, Hangzhou, China

Tel: +86-571-87688883

Fax: +86-571-87688815

Email: overseas@dahuatech.com

www.dahuatechsecurity.com

*Design and specifications are subject to change without notice.

© 2014 Dahua Technology Co., Ltd.